

Piezoelectric accelerometer

Model 6245

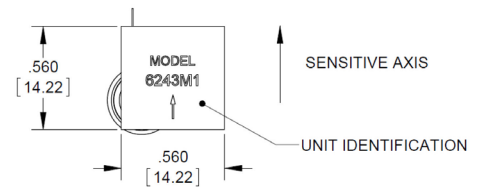
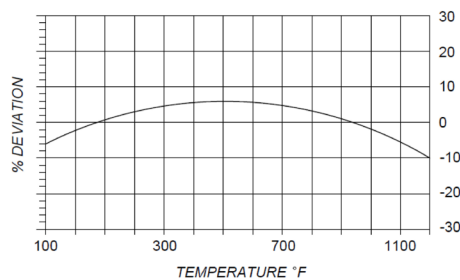
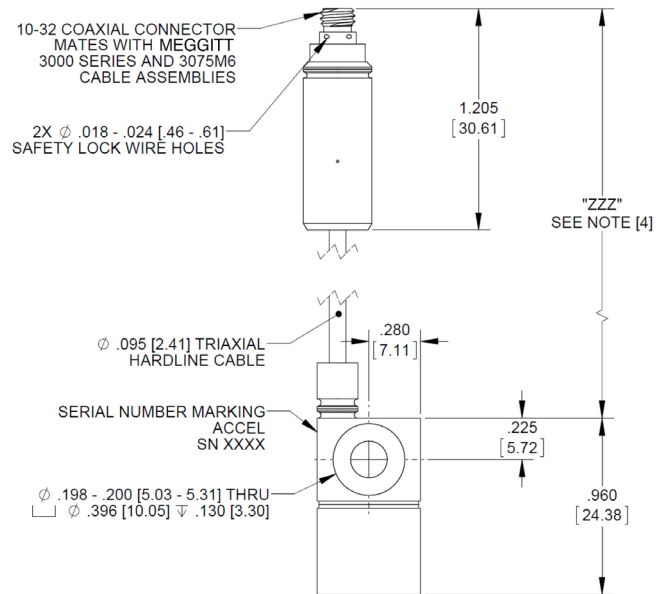
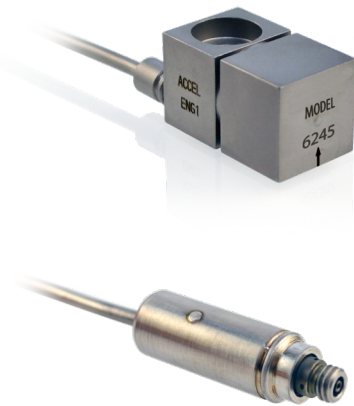

STANDARD TOLERANCE
INCHES [MILLIMETERS]
.XX = \pm .02 [X = \pm .5]
.XXX = \pm .010 [XX = \pm .25]

Key features

- +1500°F (+815°C) operation
- Integral hardline cable
- Hermetically sealed
- No pyroelectric or thermal velocity spiking
- Single bolt mount
- Ground isolated

Description

Meggitt model 6245 piezoelectric accelerometers are designed specifically for use in extremely high temperature environments such as aircraft and ground-based gas turbines. These accelerometers are designed for continuous operation at +1500°F (+815°C) and intermittent. The small size and light weight of these accelerometers facilitate installation in cramped locations with minimal structural support.

The 6245 incorporate Meggitt's MC2 shear mode crystal. The 6245 has its sensitive axis located in line with the mounting screw. The sensing elements and integral shield are isolated from the case. The accelerometer features an integral hardline cable of customer specified length, in which the standard length is 120 inches. The cable is triaxial with the termination of the signal positive and negative leads through a 10-32 coaxial receptacle. The connector is designed to operate in an environment up to +900°F (+482°C).

Piezoelectric accelerometer

Model 6245

Specifications

The following performance specifications conform to ISA-RP-37.2 and are typical values, referenced at +75°F (+24°C) and 100 Hz, unless otherwise noted. Calibration data, traceable to National Institute of Standards and Technology (NIST), is supplied.

Dynamic characteristics	Units	6245
Charge sensitivity		
Typical	pC/g	3
Tolerance	pC/g	±0.5
Frequency response		
Resonance frequency		
Typical	kHz	11
Minimum	kHz	9
Typical amplitude response [1][2]		
±5%	Hz	1 to 3000
±10%	Hz	1 to 4000
±3dB	Hz	1 to 6000
Temperature response		See typical curve
+1500°F (815°C) max/min	%	±15
Transverse sensitivity	%	≤5
Amplitude linearity per 500g, 0 to 2000 g	%	1
Electrical characteristics		
Output polarity		Acceleration in direction of arrow marked on unit produces positive output
Resistance		
Pin to pin at 1200°F [3]	kΩ	≥10
Isolation, pin to case, at 1200°F	kΩ	≥500
Hardline cable, two places at 1200°F (650°C)	kΩ-ft	100
Capacitance		
Transducer, excluding hardline cable	pF	50
Hardline cable, center conductor to inner shield	pF/ft (pF/m)	100 (328)
Dielectric strength	V	500
Grounding		Signal return isolated from case
Environmental characteristics		
Temperature range		
Transducer/hardline cable	°F (°C)	+1500°F (+815°C)
Connector	°F (°C)	-65 to +900 (-55 to +482)
Humidity		Hermetically sealed
Sinusoidal vibration limit	g	500
Shock limit	g	2000
Physical characteristics		
Dimensions		See outline drawing
Weight excluding cable	grams (oz)	30 (1.1)
Case material		Inconel
Hardline cable		Triaxial, 0.095 inch diameter, Inconel jacketed, mineral oxide insulated
Cable minimum bend radius	Inches	0.25
Connector		10-32 coaxial
Mounting torque	lbf-in (Nm)	18 (2)
Calibration data supplied		
Charge sensitivity	pC/g	
Frequency response	%	50 to 3000 Hz
Transverse sensitivity	%	
Capacitance	pF	

Piezoelectric accelerometer

Model 6245

Accessories

Product	Description	6243MX
Meggitt 874	Mounting screw (10-32 x 0.75 in, 12 pt)	Included
3090C-ZZZ	Cable assembly, +500°F (+260°C)	Optional
Meggitt 3075M6-ZZZ	Cable assembly, +900°F (+482°C)	Optional
2721B	Signal conditioner	Optional
2771CM2-1	Remote charge converter	Optional
Meggitt 3076-ZZZ	Cable assembly, high temp softline, +1000°F (+538°C)	Optional

Notes

- Frequency response is controlled by the resonance characteristics of the transducer. Estimated calibration errors are $\pm 1.5\%$ to 900 Hz and $\pm 2.5\%$ from 900 Hz to 5000 Hz.
- Low-end response of the transducer is a function of its associated electronics.
- The electrical resistance of piezoelectric materials decreases with an increase in temperature and can approach $10,000\Omega$ at $+1200^\circ\text{F}$ ($+650^\circ\text{C}$).
- Dash number "ZZZ" indicates the cable length in inches. See table below for tolerance on the cable lengths for the 6245.

Length "ZZZ"

Up to 72.00 inches (1.83 m)

Over 72.00 inches (1.83 m) to 144.00 in (3.66m)

Over 144.00 inches (3.66 m)

Tolerance

± 2.00 inches (50.8 mm)

± 4.00 inches (101.6 mm)

± 4.00 inches (101.6 mm) per 144.00 inches (3.66 m) or part thereof

- Intermittent temperature exposure is defined as 5 minutes over a 60 minute period.
- Model number definition:

