

Energy products

Gas metering valve C327835

1½-inch flange, 150 to 200 vdc,
electromechanically actuated (EMA)



Meggitt's 1½-inch globe style gas metering valve is in use on a variety of industrial gas turbine engines. With millions of field operating hours, this design continues to prove the high reliability of Meggitt EMA technology.

Specifications

Function: Precision Fuel Gas Metering for aero-derivative turbine engine control

Physical size: 9.88" flange to flange, 23" high

Weight: 75 pounds

Flange type: 1.5" ANSI B16.5 CL 600 raised face flanges

Line pressure: 0 to 600 psig

Fluid temperature: 0 to 400°F

Ambient temperature: -40 to 220°F

Performance:

Flow: Linear trim, 0 to 4.0 pounds/sec natural gas, $C_v = 40$

Pressure drop: 25 psid maximum (3.5 pounds/sec, 500 psig)

Leakage: ANSI class IV

Operating time: 100 msec full stroke response, 300 msec fail-safe closed

Electrical:

Motor: Steady state, 75 watts, 150 to 200 VDC, 0.30 amperes; peak (100 msec); 1200 watts, 8 amperes maximum

Resolver: 4 VAC, 25 to 60 ma maximum

Position switch: 20 to 32 VDC, SPDT

Actuator also available in 90 to 130 VDC version

Key features

- Exceptional accuracy, $\pm 1\%$ of flow point
- High speed brushless DC servo motor performance, 20 Hz frequency response
- 100 msec full stroke response time
- Used on both DLE and SAC turbine engines
- Explosion proof design, CSA/UL certified for NEC class 1, division 1, groups C and D, temp code T4, CENELEC zone 1, EExd IIB
- All stainless steel valve and yoke materials for NACE compliance
- No maintenance required under normal conditions

Meggitt Control Systems

Our product competencies & services:

Aerospace valves | Thermal management solutions | Environmental control systems | Electro-mechanical products
Ground fueling products | **Energy products** | Aftermarket services

MEGGITT
smart engineering for
extreme environments

Energy products

Gas metering valve C327835

Key dimensions

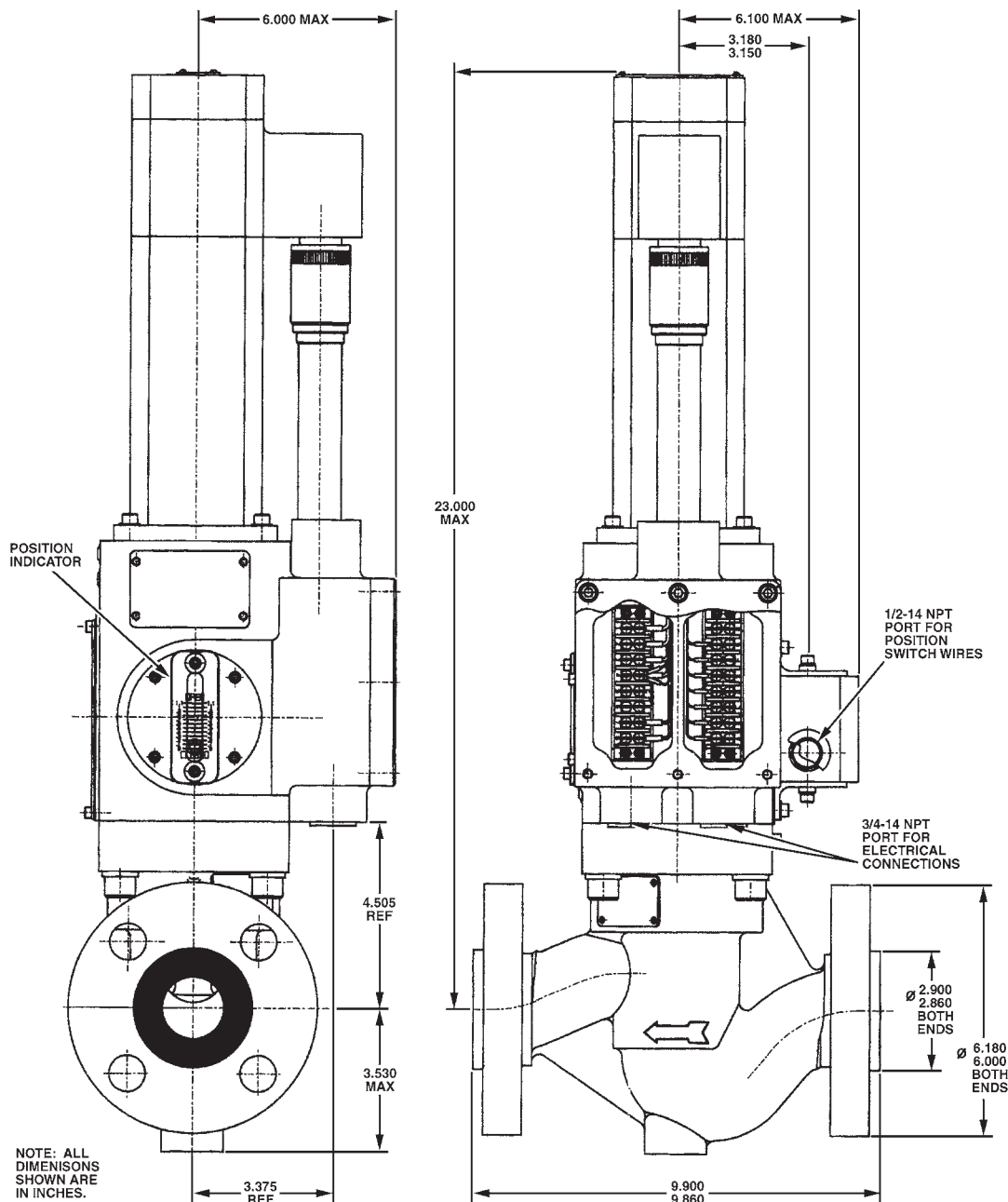

Contact

Meggitt Controls

12838 Saticoy St
North Hollywood
California 91605-3505
USA

Telephone: (818) 765-8160
FAX: (818) 759-2194

www.meggitt.com

Meggitt Control Systems

Our product competencies & services:

Aerospace valves | Thermal management solutions | Environmental control systems | Electro-mechanical products
Ground fueling products | Energy products | Aftermarket services

MEGGITT
smart engineering for
extreme environments